

Sanezoo Coating

Visual inspection
of painted surfaces



Sensing device

Key parameters

Sanezoo Coating is a specialized system for reliable detection of visual defects such as scratches, dust inclusions, pores, runs, uneven coating coverage, and structural paint anomalies.

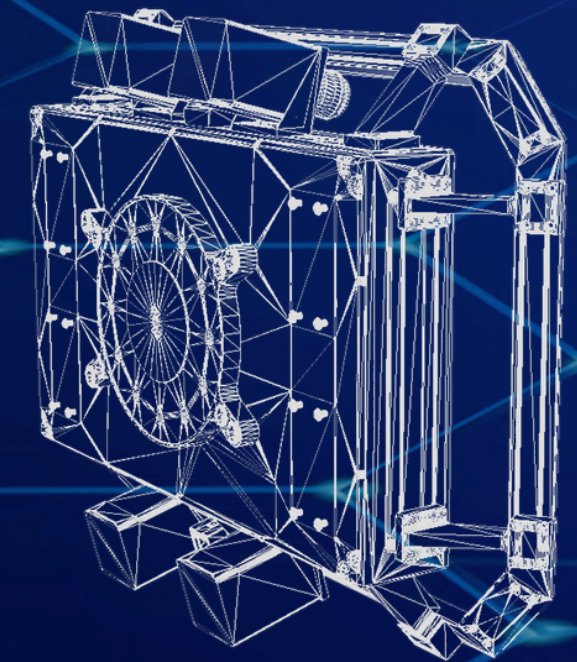
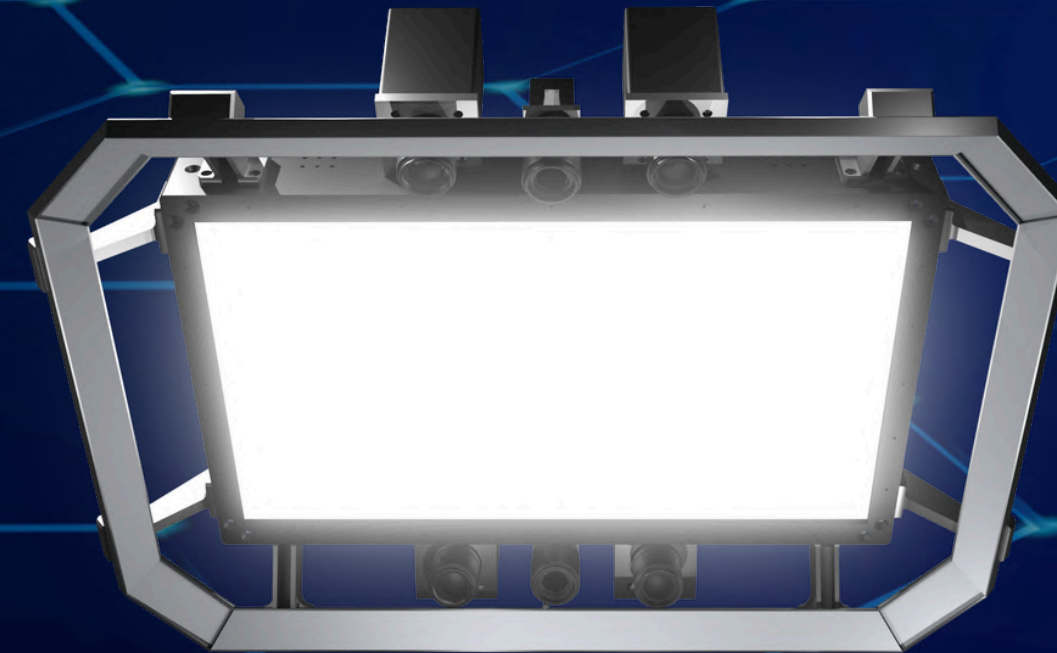
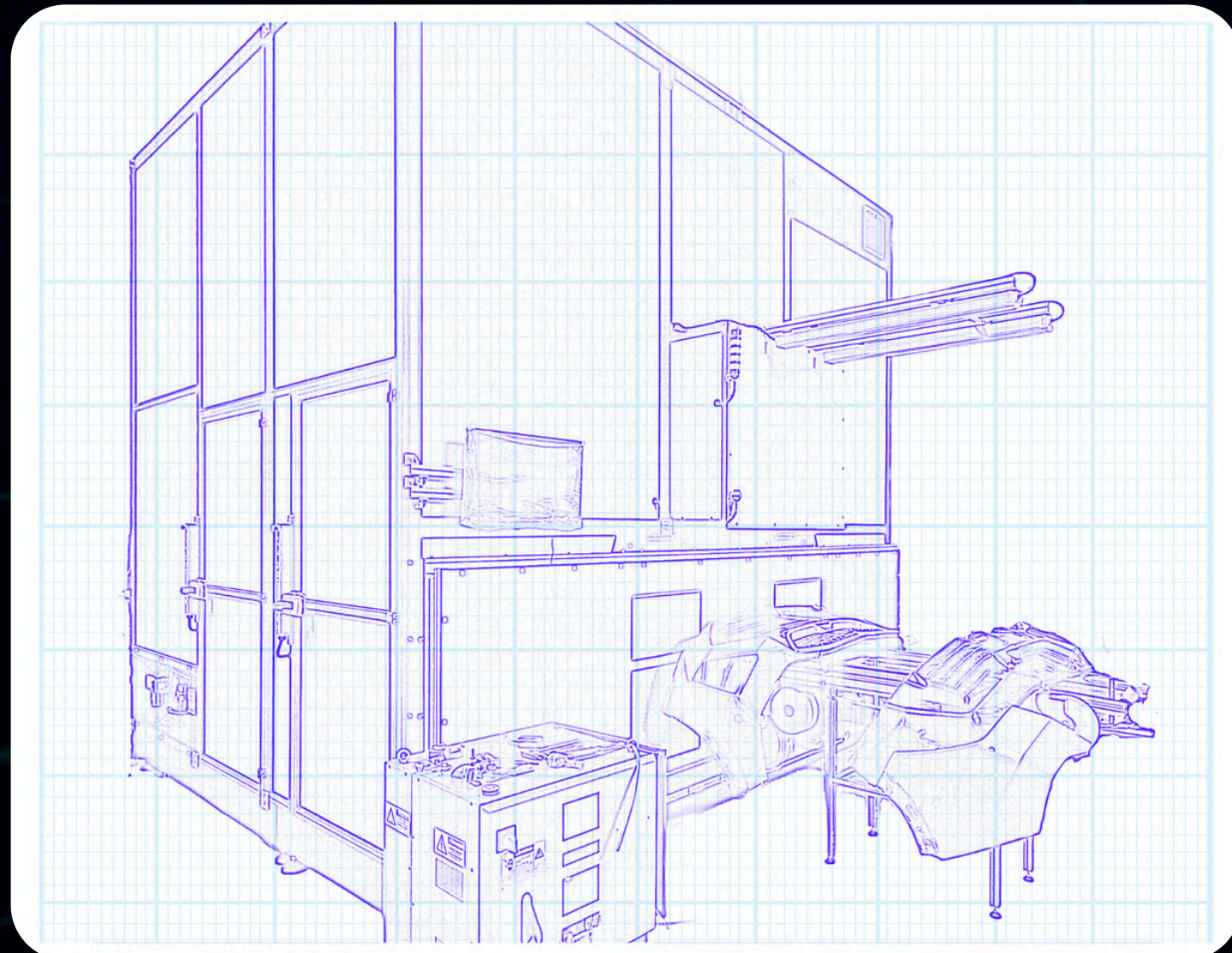

Scanning time
800 microseconds

Minimum defect
0.03 mm

Cycle time
~3 s incl. AI analysis



Key features

Sanezoo Coating

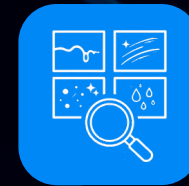
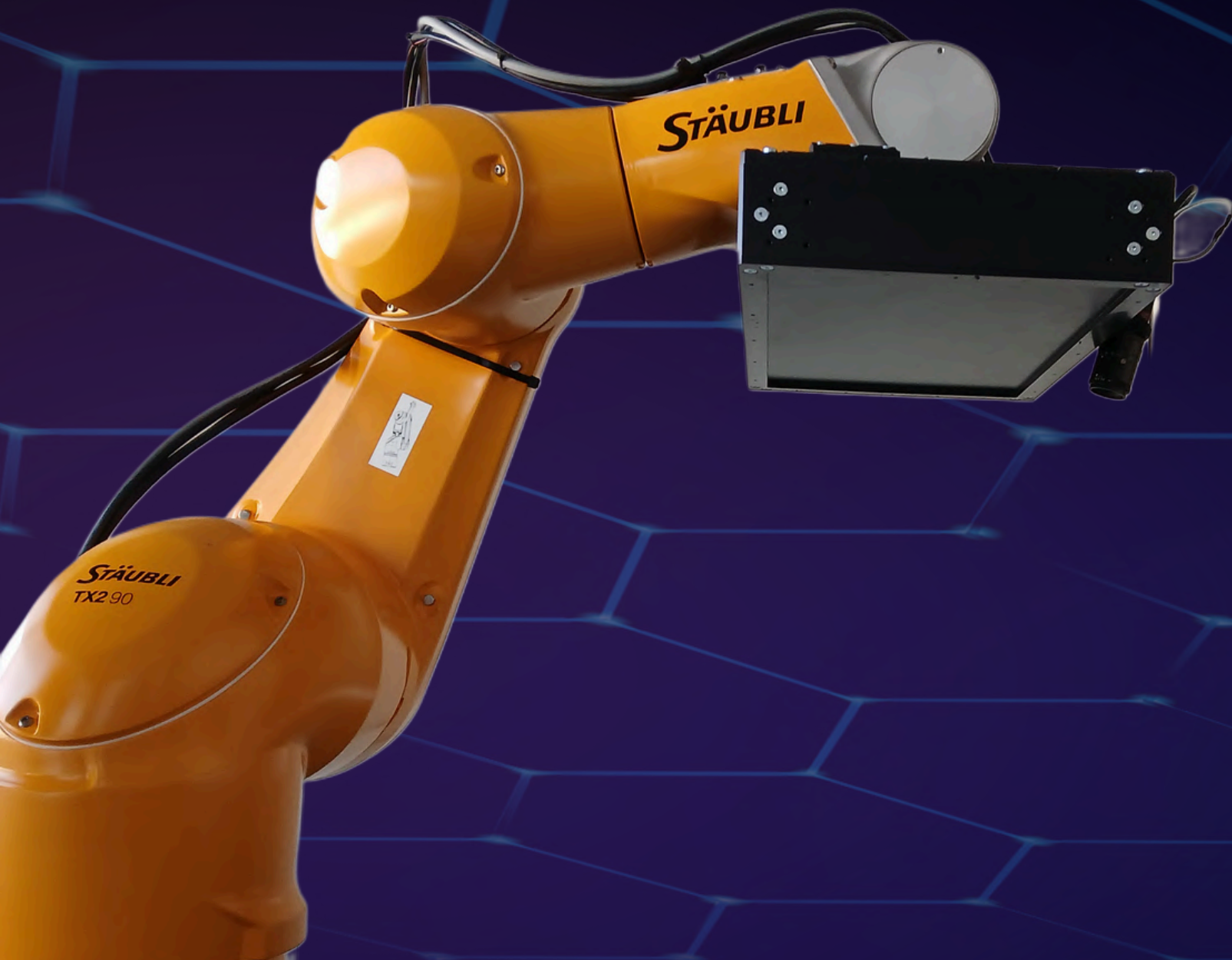

Basic classification of painted surface defects based on visual characteristics



Parameterization of countable and NOK defects for quantitative evaluation



Reliable detection of structural, mechanical, and coating defects from 0.03 mm



Detection across the full color spectrum, including metallic and matte paints



Static or robotic integration into production environments



Individual parameter configuration per product type



Short cycle time even for large parts thanks to 0.0008 s exposure enabling motion capture



Typology of detected defects

Sanezoo Coating enables systematic detection of paint defects based on their visual characteristics. The system not only detects the presence of a defect but also allows its quantification and classification according to defect type.

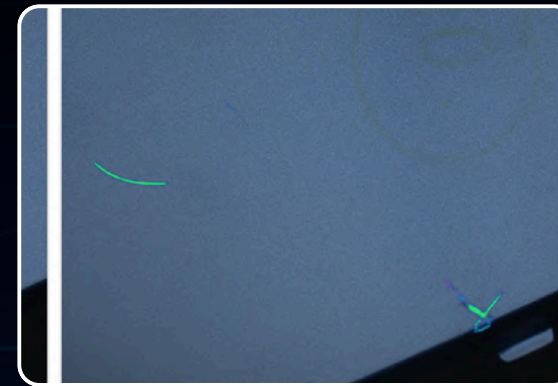

scratches

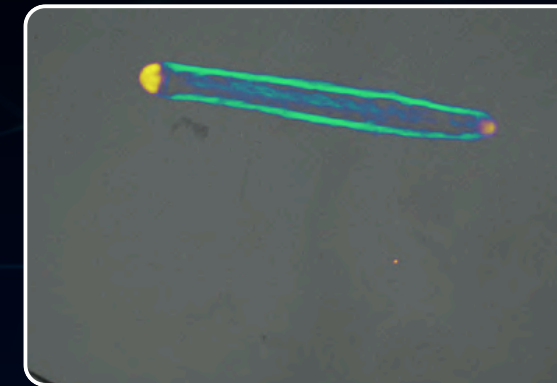

paint drops

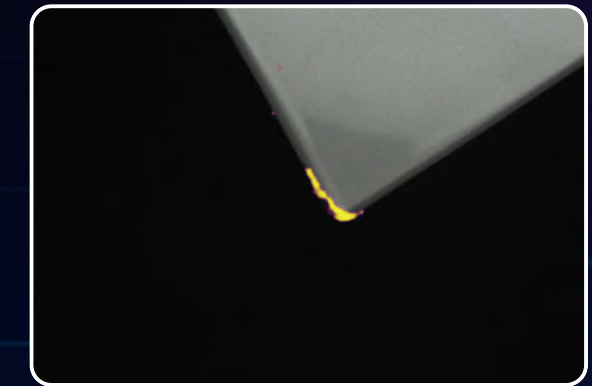

edge defects

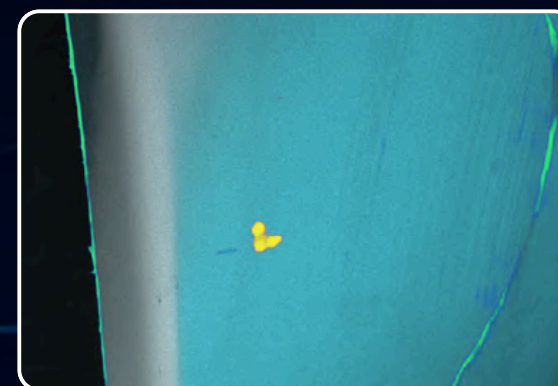

dirt under the paint

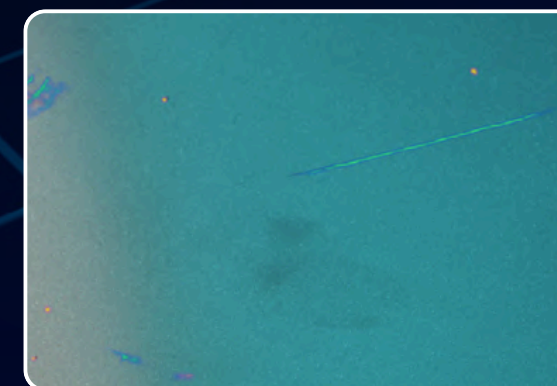

needle punctures



holes

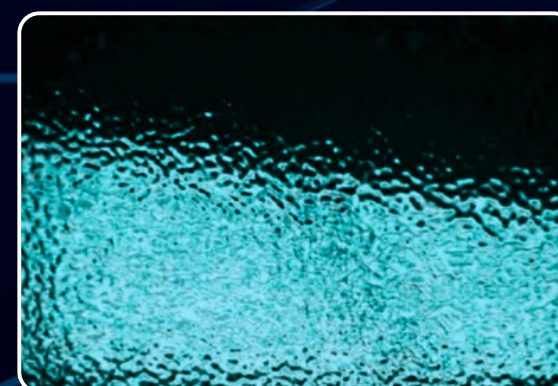

orange peel



coated particles



other impurities



Coverage optimization

Controlled viewpoint positioning for maximum visual accessibility

Sanezoo Coating operates on the principle of controlled viewpoint configuration to achieve the highest possible coverage of the inspected surface without the need for complex mechanical repositioning of the part. In robotic configurations, the system defines a sequence of inspection positions that minimize shadowed areas, contrast loss, and optical blind spots.

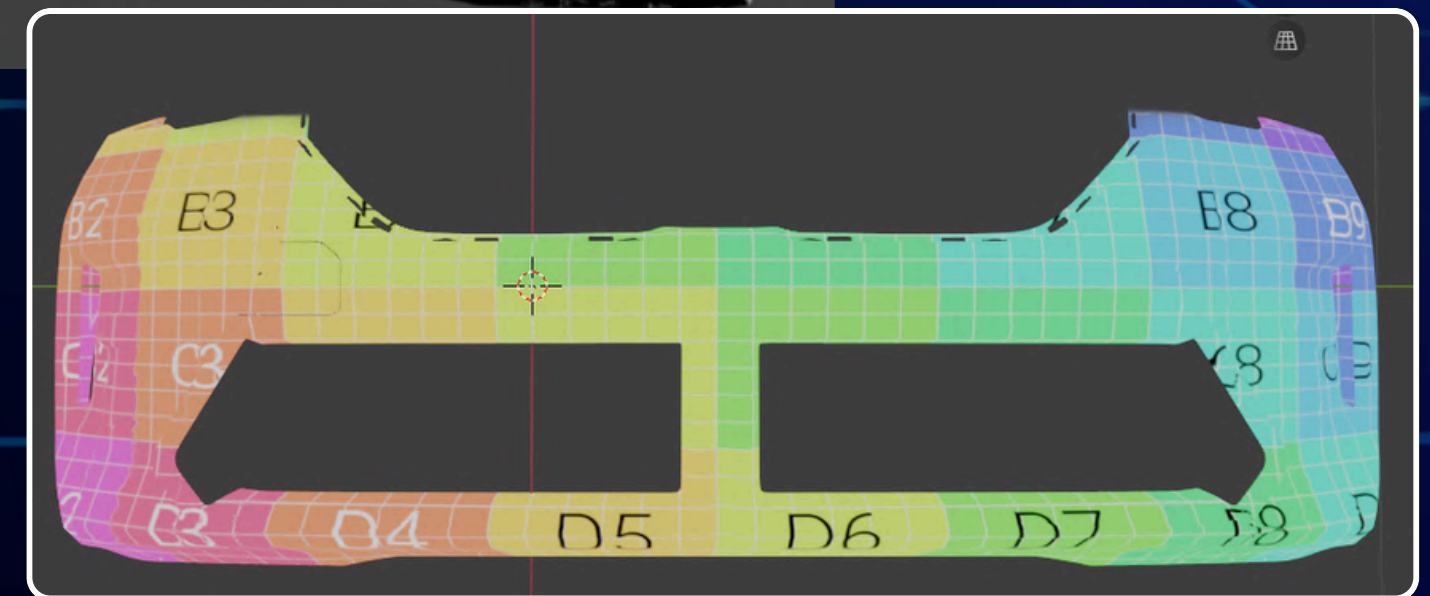
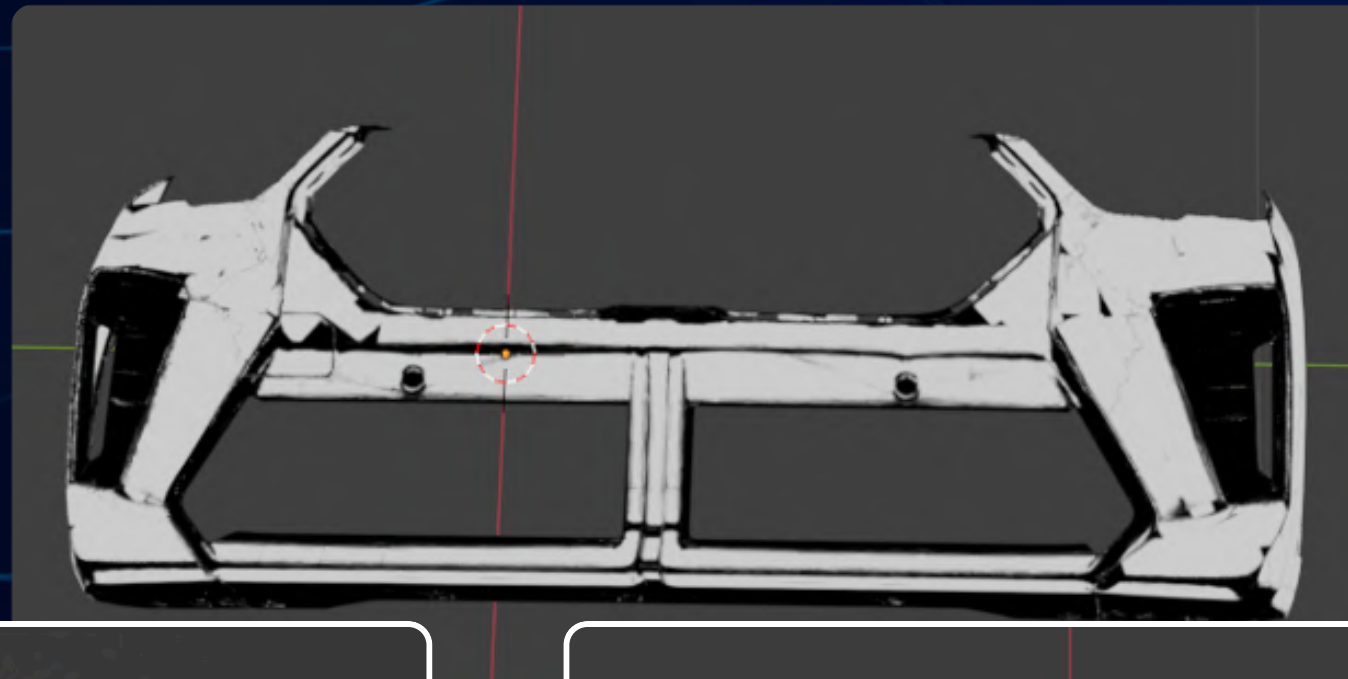
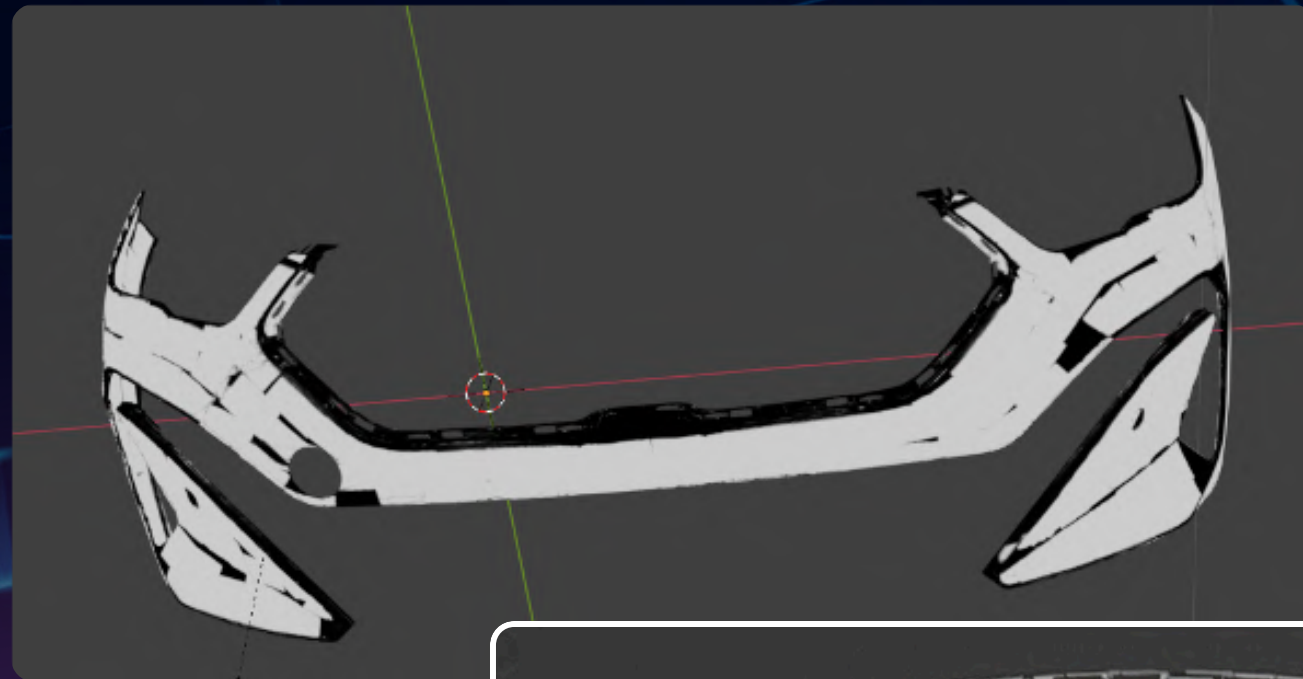

Examples of analytical outputs

Clear data for quality management

The system does not provide only an OK/NOK result; it also generates clear analytical outputs that help better understand the quality of the manufacturing process.

It allows evaluation of the inspection coverage and optimization of the number of inspection viewpoints to ensure high inspection quality while maintaining a reasonable cycle time.

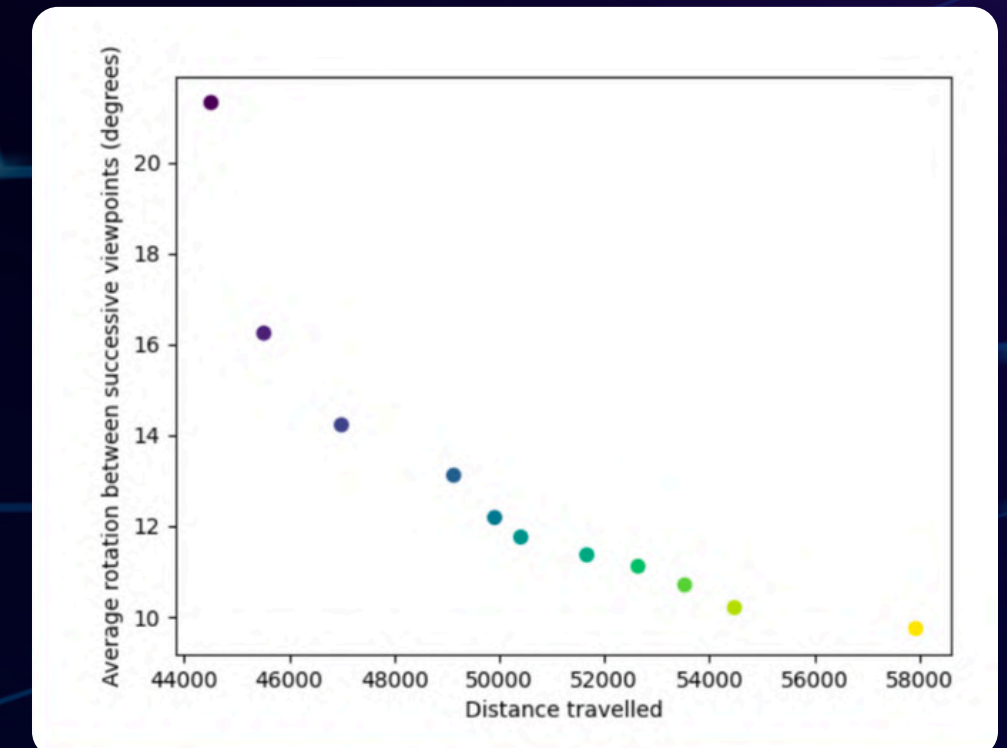
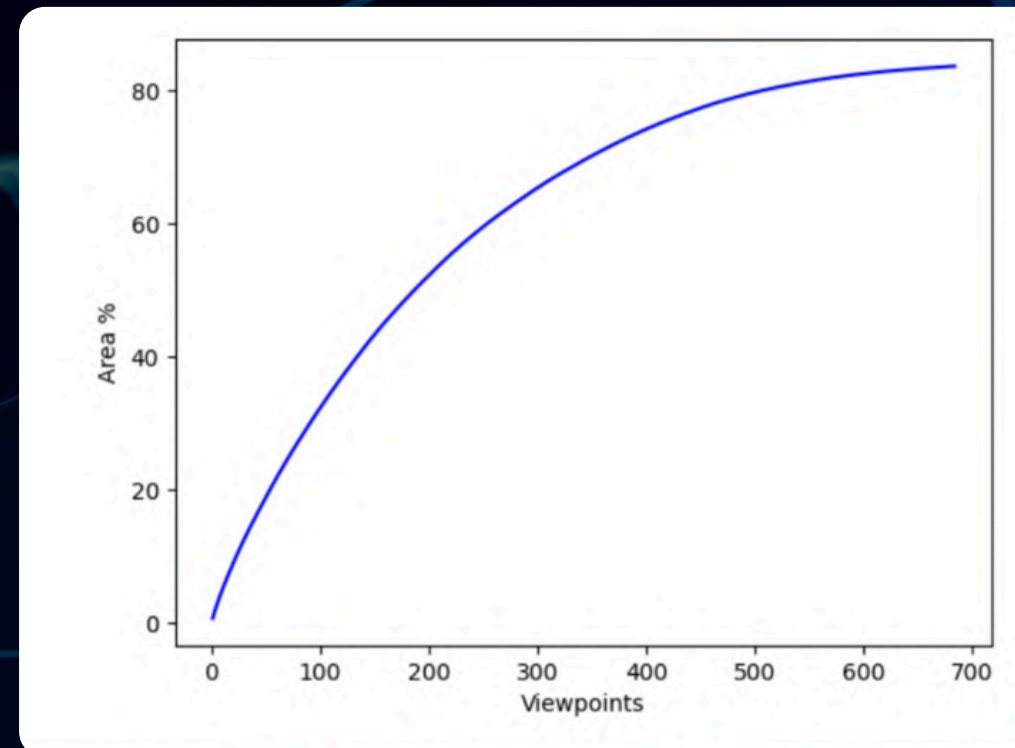

Sanezoo Studio

Configuration without programming

Sanezoo Studio enables easy configuration of SANEZOO Coating, providing user-friendly setup options and seamless integration into various production environments. Changes in the product or coating process can be reflected by adjusting the configuration without requiring major system modifications.

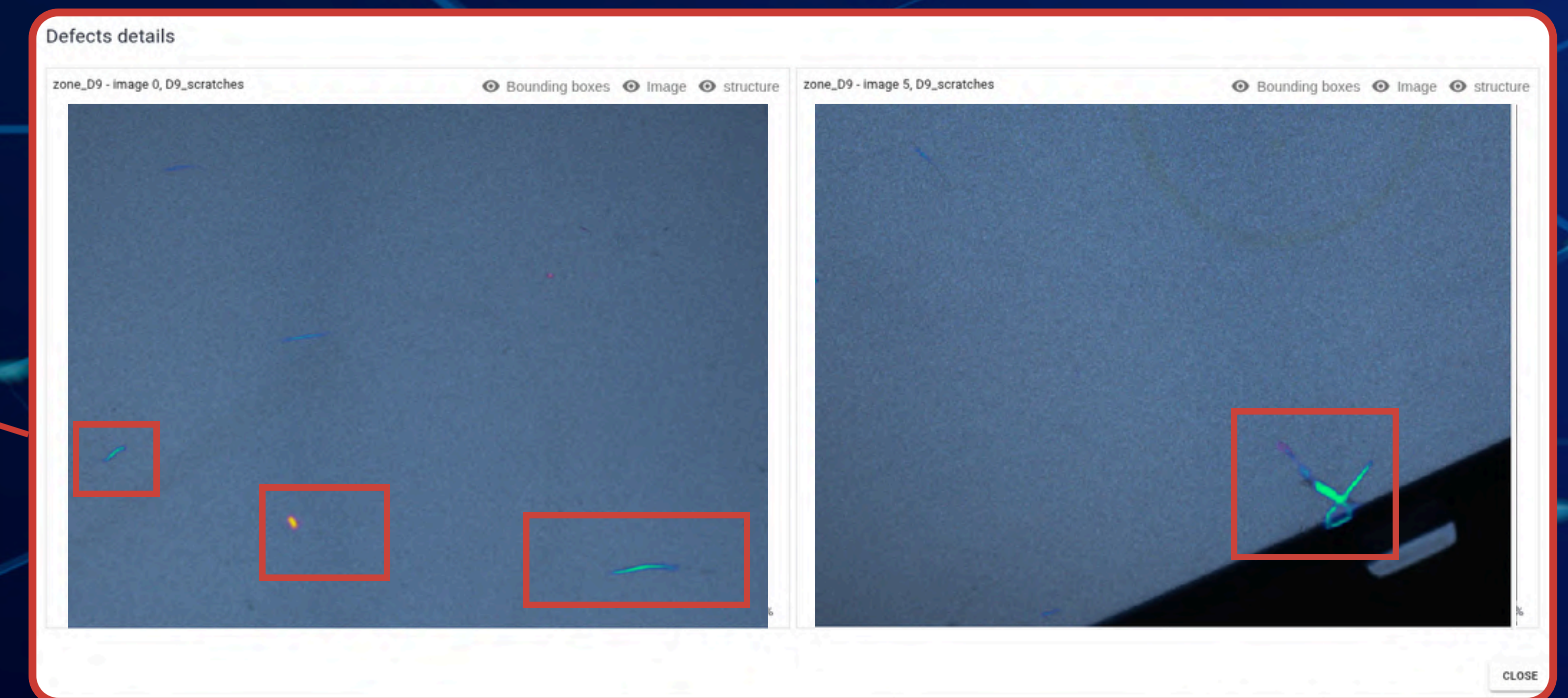
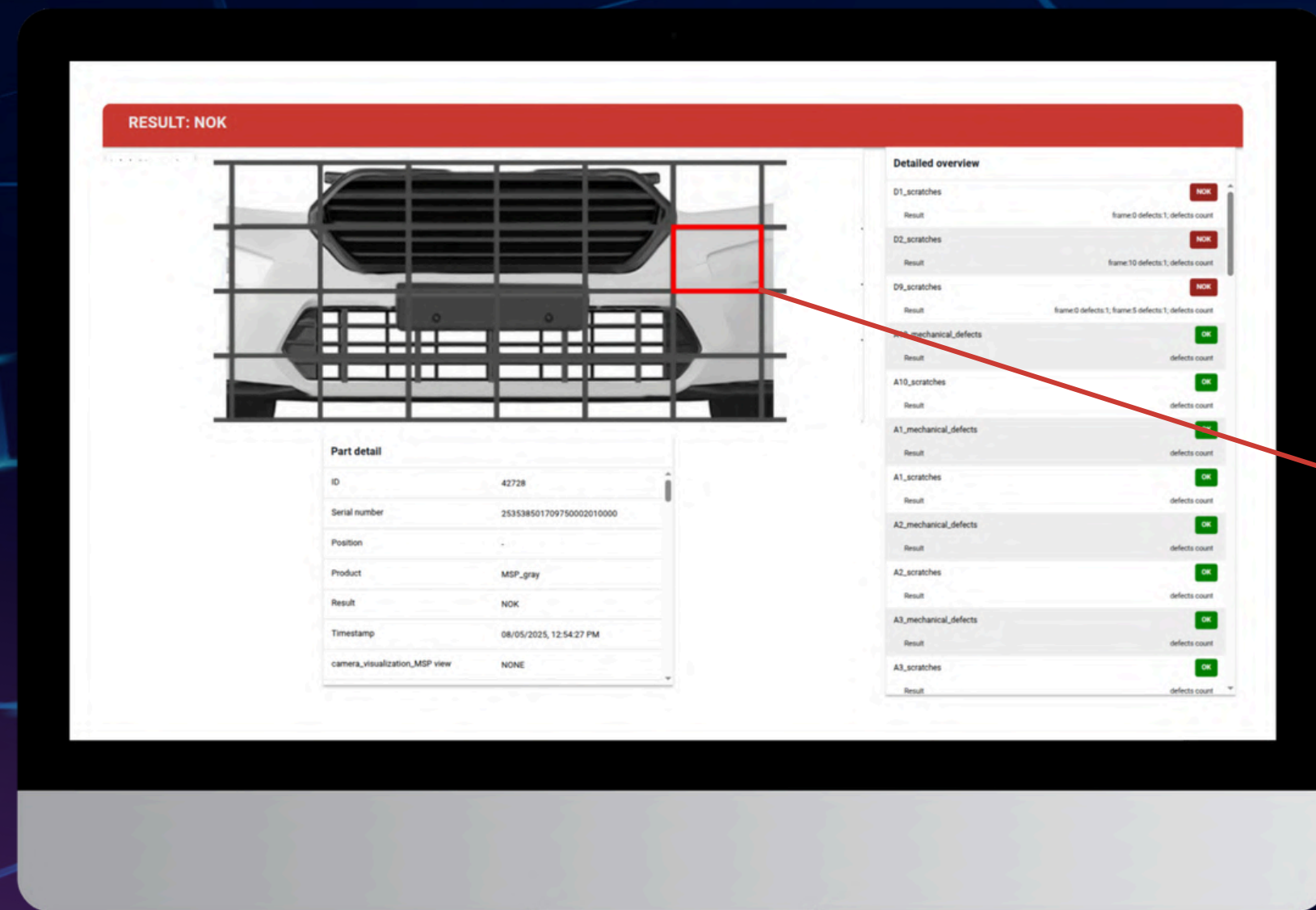

Parameterization and quantitative evaluation

The system allows configuration of:

- minimum defect size
- maximum number of defects within a defined area
- different tolerances depending on defect type
- overall limits for the entire part

Defects can be categorized as countable or critical (NOK). The decision is not purely binary but is based on quantitative evaluation of defined parameters.

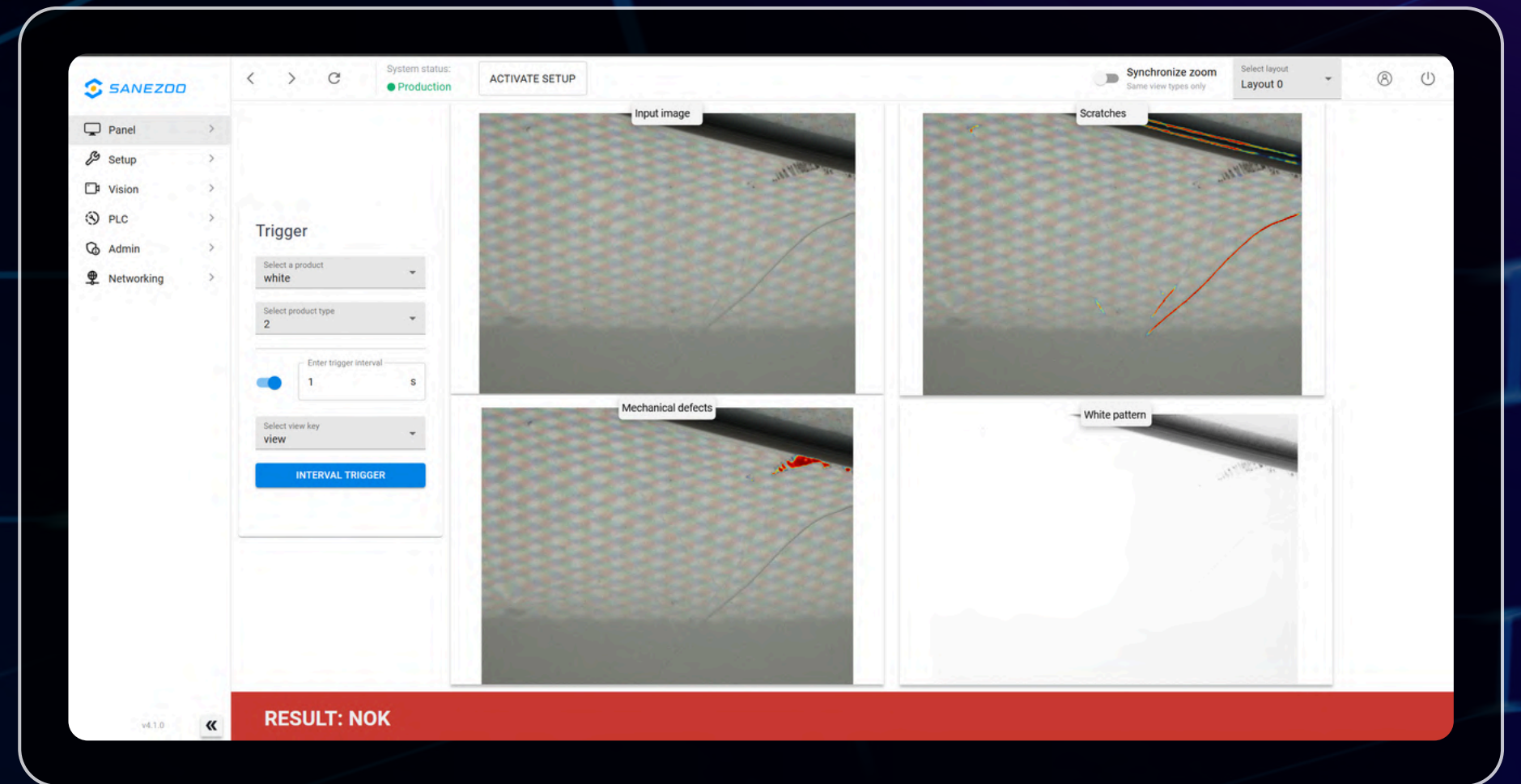

Why choose Sanezoo

Comprehensive solutions for any task

Thanks to proprietary software and hardware development, we design solutions tailored to specific production conditions.

The combination of both layers creates a unified platform capable of addressing a wide range of industrial requirements — not limited to a single use case.



Stable quality with fast return of investment



Modular architecture

The system can be easily extended with new functionalities according to evolving needs



Controllable platform

Application logic is built from combinable modules that can be freely chained and modified



One system, endless possibilities

Unified environment for all applications — no need to train personnel on multiple separate systems



Proven ROI

Investment typically returns within 10 months through labor savings and reduced scrap rates



Margin & reputation protection

Systematic quality control eliminates unnecessary warranty costs and strengthens customer trust



References and awards

Trusted by leading industrial companies and recognized at international trade fairs.





SANEZOO®

Teach Cameras to Think

SANEZOO SE

Czech Republic

Vlněna 526/7,

602 00 Brno

+420 604 276 216

sales@sanezoo.com

sanezoo.eu

